

Definition

The CMCE-MARINE is a Protection System Against Atmospheric Discharges THAT PREVENTS THE FORMATION OF LIGHTNING, whose operating principle is based on balancing or compensating the variable electric field existing in its environment, avoiding the generation of the UPWARD TRACER.

Maximum working voltage of the CMCE-MARINE without lightning discharge

515.41 KV at one meter, according to high voltage laboratory tests (UNE 21186: 2011 // NF C17-102: 2011).

Maximum permissible short-circuit current

The tests carried out according to IEC-10/350 Q power curves of 100,000 Amps, specified in the IEC-62305 standards, show that the equipment can withstand 7 continuous discharges of 89,906KA; 89.62KA; 88.53KA; 89.3KA; 90.44KA; 96,656KA; 89,688KA; without suffering breakage of materials or marks of deterioration or perforation.

Product warranty

Annual maintenance or according to the frequency established by the manufacturer based on the specifications of the boat. Maintenance is mandatory, carried out and certified by the official installer. 5-year product warranty due to manufacturing defect, justifying maintenance with the established frequency.

Protection efficiency

99% reduction of direct lightning impact on the protected structure. In case of direct lightning strike (1%) or indirect effects by external induced overvoltages on the protected structure, the CMCE-MARINE behaves like a thermal fuse, absorbing part of the lightning energy in heat by melting its components, reducing to a minimum (between 60% - 90%) electromagnetic effects.

Materials that compose it

Recycled Aluminum, Insulator: Polyacetal, also called polyoxymethylene (POM). It does not contain electronic components, heavy metals or radioactive.

Connection system to the mast or manufactured support:

It incorporates the mast connection system on its axis. The CMCE-MARINE requires an internal \varnothing 42 mm and an external \varnothing 49 mm mast with a \varnothing 8 mm through hole at 32 mm from the edge of the mast. For a manufactured support, it must have a minimum thickness of 3.2 mm (It may vary depending on the model, for more detailed information consult the manufacturer).

CMCE Product Certificate

- ISO 9001-2015 Certificate
- ISO 14001-2015 certificate
- SERTEC SRL is approved within the NATO Cataloging System (NOC) with the NCAGE code SFKU3 for our CMCE SERTEC lightning rods
- DUNS REGISTRATION Number 955067967
- CE MARKING on all CMCE models.
- UKCA MARKING on all CMCE models
- RoHS is EN IEC 63000: 2018 "Technical documentation for the evaluation of electrical and electronic products with respect to the restriction of hazardous substances"
- We have UL-Certification on a specific model.

ENAC; ILAC-MRA-ITE Laboratory - Spain

- A.1. General tests (Section 3.1 UNE21186: 2011 // NF C17-102: 2011)
- Test: Documentation, information and identification (C.3.1.1)
- Test: Marked (C.3.1.2)
- A.2. Mechanical tests (Section c.3.2 UNE 21186: 2011 // NF C17-102: 2011) - Test: Mechanical tests (C.3.2)
- A.3. Environmental tests (Section C. 3. 3 UNE 21186: 2011 // NF C17-102: 2011) - Test: Salt mist test (C.3.3.1) - Test: Test in a humid sulfurous atmosphere (C.3.3.2)
- A.4. Current test (Section 3.4 UNE21186: 2011 // NF C17-102: 2011) - Test: Current test (C.3.4)
- A.5. Priming advance tests (Section c.3.5 UNE 21186: 2011 // NF C17-102: 2011) - Test: Determination of the advancement in the priming of the PDC (C.3.5 .3 UNE 21186: / C.3.5.2.4 NF C17-102: 2011)



TECHNICAL SPECIFICATIONS CMCE-DIAMOND



Non-polarized electrode designed for lightning protection in all types of vessels, including facilities with risk of fire or explosion.
COMPLIES WITH THE IEC 62305 PART 1, 2, 3 STANDARD.

OPERATING PRINCIPLE:

Compensation of the electric field in its environment.

CONNECTION SYSTEM TO THE MAST OR SUPPORT:

It incorporates in its axis the system of direct connection to the mast or for the support.

MAXIMUM WORKING VOLTAGE WITHOUT LIGHTNING

515.41 KV at one meter.

MAXIMUM INTENSITY

100 kA tests according to IEC-10/350 μs CMCE-MARINE.

Applications

With great deionizing power, it is developed for maximum protection in Yachts, Cruises, Catamarans, Cargo Ships, Military Ships, etc.

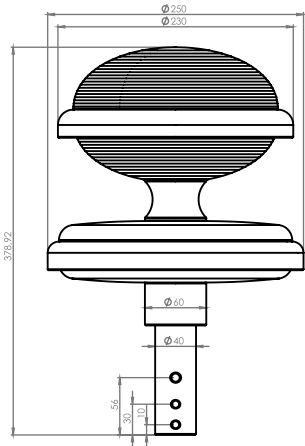
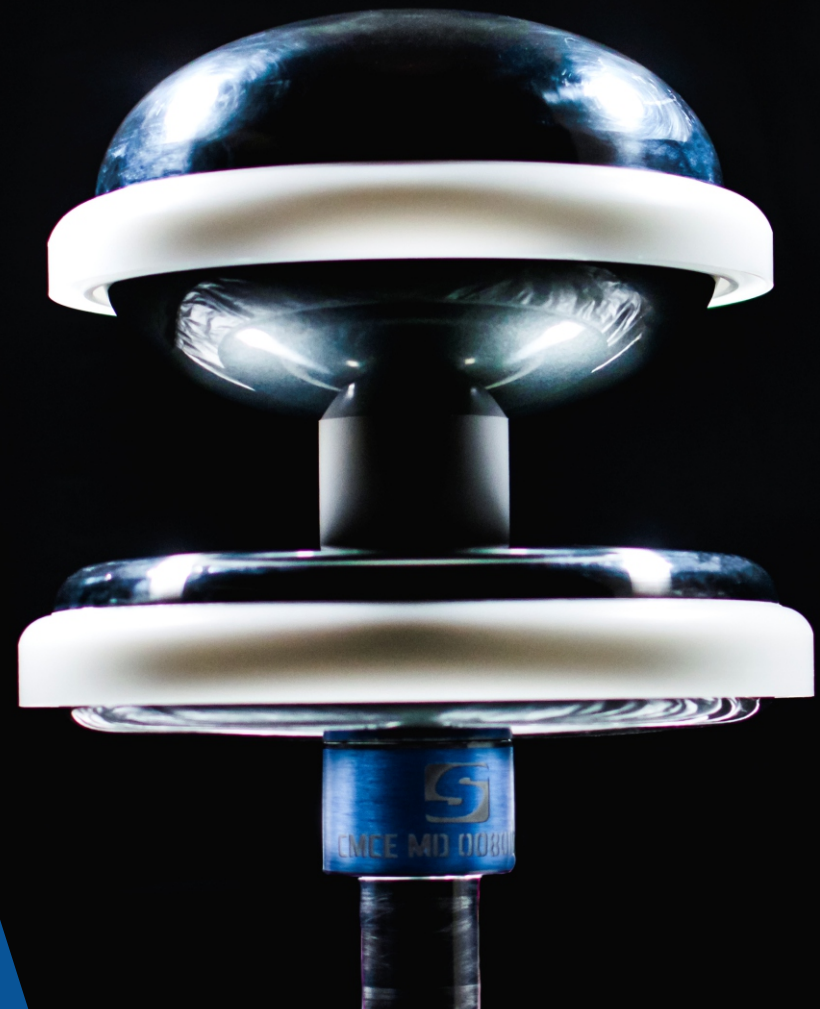

WEIGHT / MEASURES OF THE CMCE-MARINE

Weight: 6,170 kg (Bruto)

Measurements: 25cm x 37.8cm

